

Have you considered **to upgrade your sheet metal work?**

Take your metalworkers to advanced technology!



GALT
FORMING

WEST FORMING SOLUTIONS

A technological innovation offered by **WEST FORMING SOLUTIONS**

Still entangled in ancestral processes for straightening and conforming?



Take your metalworkers to advanced technology!

- ▶ Better **productivity**,
- ▶ Higher **quality**,
- ▶ **Noise reduction** for a better work environment,
- ▶ **Elimination of risks** related to musculoskeletal disorders.

A technological innovation offered by **WEST FORMING SOLUTIONS**

Motorized roller burnishing machines with an ergonomic shape for all metalworkers of the aircraft industry



With traditional methods

Traditional methods (hammers, mallets...) used for straightening and conforming operations are linked with **numerous issues for your operators and processes:**

Loss of surface condition

Shoulder pains for the metalworkers

Incapacity for some metalworkers to use the mallet after some working period

Waste of time during a new tuning

Uncontrolled process, that remains highly linked to the know-how of the metalworker

High noise level...



Galt Forming: a new straightening and conforming technology with roller burnishing

Motorized Galt Forming equipment with perfect ergonomic design **improves the quality of your industrial processes:**

Optimized repeatability

thanks to an upstream set-up of process plans.

Effortless operation

for the operator thanks to a motor-assisted straightening and lengthening process.

Quality increase of produced parts

the straightening operation covers larger areas, the pressure applied is lower without any impact effect.

Productivity growth

linked with operator's fatigue in case of traditional methods, and with the new tuning operations needed after the hammer impact on the workpiece.

Enhancement of noise level

with maximum 65 dB(A).

Suitable to all metalworkers

easy-to-use, with a controlled upstream setting of process plans.

WEST FORMING SOLUTIONS, a company created by HALGAND, a top-ranking subcontractor for OEM of aircraft industry since 1974, **suggests you to move on to Galt Forming!**



Reliable equipment: tried and tested at AIRBUS since 1999, entirely manufactured in France!

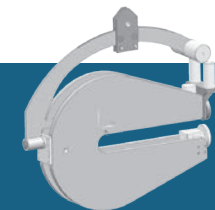
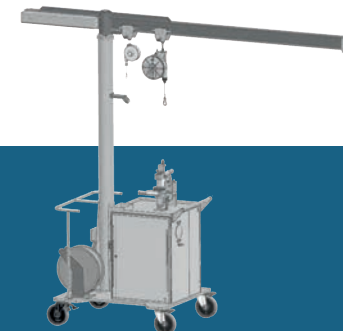
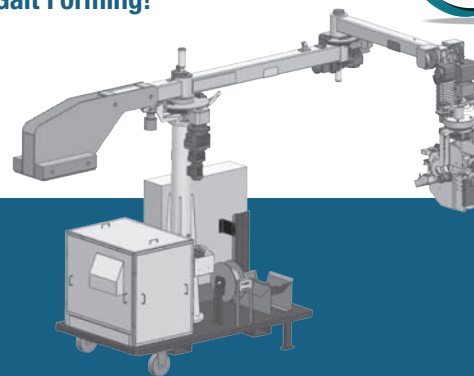

A range of equipments with crushing force from 0.2 to 20 t!

Technical Data

Model	Crushing force	Clearance without arm	Electrical Power	Supplies	Sound Level
GF1	0.2 to 3 t	1.1 x 1 m	1.5 kW	Electrical + Pneumatical	< 65 dB(A)
GF2	3 to 6 t	1.1 x 1 m	1.5 kW	Electrical + Pneumatical	< 65 dB(A)
GF3	6 to 20 t	1.4 x 2.5 m	6 kW	Electrical	< 65 dB(A)

CE standards compliant

Technical information

The metalworker easily adjusts the roller burnishing machine according to the workpiece and the final design wished. The applied force is set directly on the roller burnishing head using a potentiometer with display. The setting is repeatable for the series that follow.

According to the workpiece thickness and dimensions, we offer 3 different models. GF1, GF2, GF3.

Easy setting of the stretching force by the metalworker

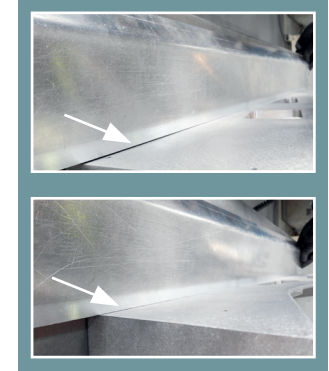
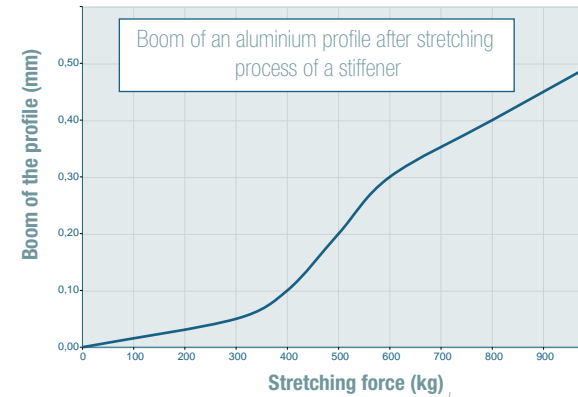

Before / After straightening operation

Position of the workpiece against the ruler to see the straightening effect after roller burnishing operation.

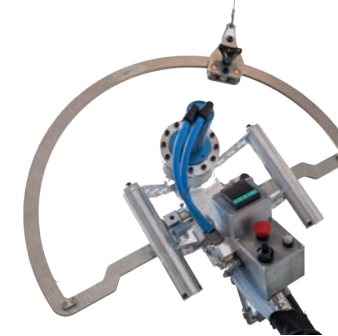

Options



A standard and well-proven technology with custom-made extra

Arm equipped with a balancer
to relieve the metalworker.

Motorized arm axes
for effortless handling.

Steerable roller burnishing head
for an easy head alignment
in horizontal or vertical position.

Many other optional features available... Contact us!

Roller burnishing head

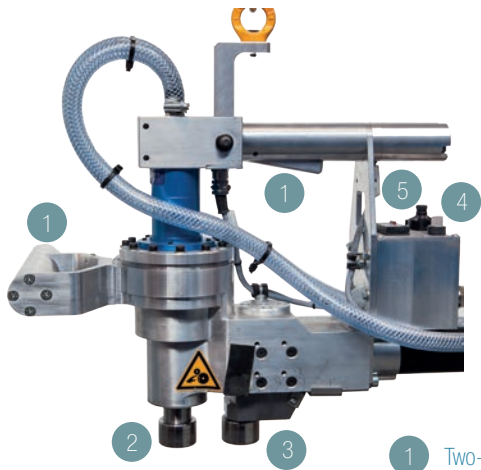

- 1 Two-hand control
- 2 Motorized roller
- 3 Clamping roller
- 4 Force adjustment
- 5 Force display

WEST FORMING SOLUTIONS

We ensure your support through each stage of your project

To meet your objectives in terms of repeatability enhancement, quality and ergonomic design of metalworking operations, **West Forming Solutions will support you throughout your integration project of a Galt Forming equipment.**

Our services:

- ▶ Project study and definition of your requirements,
- ▶ On site installation,
- ▶ Support during the tuning of your workpieces,
- ▶ Training of your metalworkers.

Additional solutions for straightening and conforming

Mobile cylinder press

The cylinder shifts laterally to ensure a conforming operation without moving the workpiece.



Mobile 3 points C

Various dimensions available with optional motorized feed for continuous conforming process.

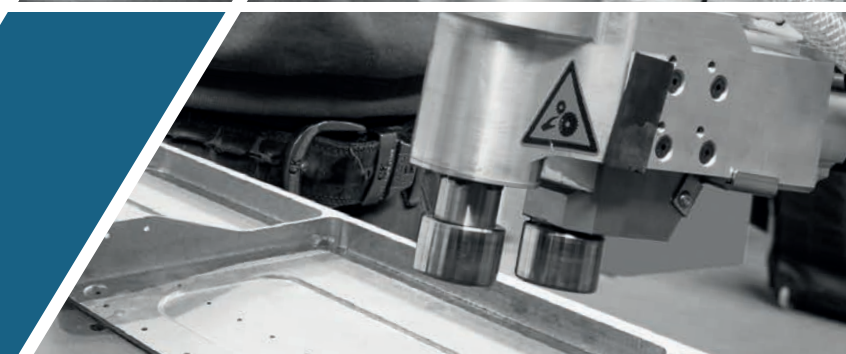

GALT FORMING



WEST FORMING SOLUTIONS

Impasse Quador
Parc d'activités de la Guerche
44250 SAINT BREVIN LES PINS
France

www.west-forming-solutions.com

Contact: Philippe LEBRIS, Sales Manager
Phone: +33 (0)2 40 64 58 44
Mobile: +33 (0)6 16 61 12 73
contact@west-forming-solutions.com

WEST FORMING SOLUTIONS, a member company of Group HALGAND.